

MOBILE POWER SOLUTIONS

CHARGERS

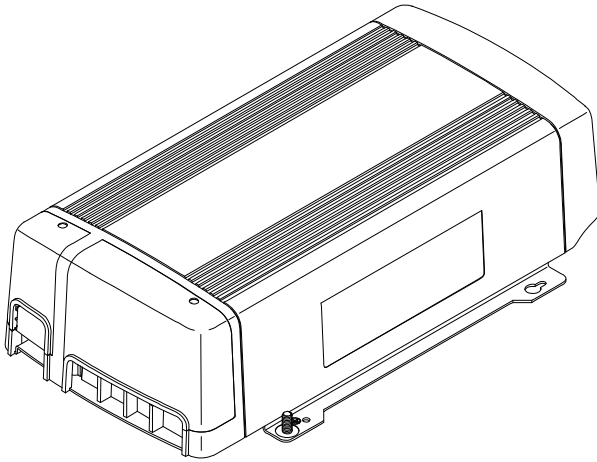

12V 100A DC-DC Charger

EN	Battery charger
	Installation and Operating Manual..... 2

English

1	Important notes.....	2
2	Explanation of symbols.....	2
3	Safety instructions.....	3
4	Scope of delivery.....	6
5	Accessories.....	6
6	Intended use.....	6
7	Technical description.....	7
8	Installation.....	12
9	Operation.....	16
10	Cleaning and maintenance.....	22
11	Troubleshooting.....	23
12	Disposal.....	26
13	Warranty.....	27
14	Technical data.....	27

1 Important notes

Please read these instructions carefully and follow all instructions, guidelines, and warnings included in this product manual in order to ensure that you install, use, and maintain the product properly at all times. These instructions **MUST** stay with this product.

By using the product, you hereby confirm that you have read all instructions, guidelines, and warnings carefully and that you understand and agree to abide by the terms and conditions as set forth herein. You agree to use this product only for the intended purpose and application and in accordance with the instructions, guidelines, and warnings as set forth in this product manual as well as in accordance with all applicable laws and regulations. A failure to read and follow the instructions and warnings set forth herein may result in an injury to yourself and others, damage to your product or damage to other property in the vicinity. This product manual, including the instructions, guidelines, and warnings, and related documentation, may be subject to changes and updates. For up-to-date product information, please visit documents.dometic.com.

2 Explanation of symbols

A signal word will identify safety messages and property damage messages, and also will indicate the degree or level of hazard seriousness.



DANGER!

> Indicates a hazardous situation that, if not avoided, will result in death or serious injury.



WARNING!

> Indicates a hazardous situation that, if not avoided, could result in death or serious injury.



CAUTION!

> Indicates a hazardous situation that, if not avoided, could result in minor or moderate injury.



NOTICE!

> Indicates a situation that, if not avoided, could result in property damage.



NOTE Supplementary information for operating the product.

3 Safety instructions

General safety

Also observe the safety instructions and stipulations issued by the vehicle manufacturer and authorized workshops.



WARNING! Electrocutation hazard

- > Do not touch exposed cables with your bare hands.
- > This device may only be repaired by qualified personnel. Inadequate repairs can lead to considerable hazards. Contact an authorized service center in case of repair.
- > If the power cable for this device is damaged, it must be replaced with a suitable power cable or assembly available from the manufacturer or its service agent to prevent safety hazards.
- > If disassembling the device:
 - Detach all connections.
 - Ensure that no voltage is present on any of the inputs and outputs.



WARNING! Health hazard

- > This device is not intended for use by persons (including children) with reduced physical, sensory or mental capabilities, or lack of experience and knowledge, unless they have been given supervision or instruction concerning use of the device by a person responsible for their safety.
- > **Electrical devices are not toys.** Always keep and use the device out of the reach of very young children.
- > Children must be supervised to ensure that they do not play with the device.
- > Cleaning and user maintenance shall not be made by children.



NOTICE! Damage hazard

- > Do **not** use the device in a salty, damp, or wet environment or immerse it in any liquids. Set up and store the device in a dry location where it is protected against splashing water.
- > Before start-up, check that the voltage specification on the data plate is the same as that of the power supply.
- > Ensure that other objects **cannot** cause a short circuit at the contacts of the device.

Installing the device safely



WARNING! Electrocutation hazard

- > Installation and removal of the device may only be carried out by qualified personnel in accordance with the national wiring regulations.
- > When positioning the device, ensure that the supply cable is not trapped or damaged. Crushed cables can lead to serious injury.



WARNING! Explosion hazard

- > Do not set up the device in areas where there is a risk of gas or dust explosion.



CAUTION! Risk of injury

- > Ensure that the device is stable. The device must be set up and secured in such a way that it cannot tip over or fall down.
- > When positioning the device, ensure that all cables are suitably secured to avoid any form of trip hazard.

Safety when connecting the device electrically



DANGER! Electrocutation hazard

- > If you are working on electrical systems, ensure that there is somebody close at hand who can help you in emergencies.



WARNING! Fire hazard

- > Observe the recommended cable cross-sections, cable length and fuse(s).



CAUTION! Fire hazard

- > Place the fuses near the batteries to protect the cable from short circuits and possible burning.



NOTICE! Damage hazard

- > Use ductwork or cable ducts if it is necessary to lay cables through metal panels or other panels with sharp edges.
- > Do **not** lay the cables so that they are loose or heavily kinked. Lay the cables so that they cannot be damaged by doors or hoods.
- > Ensure that the negative and positive poles never come into contact.
- > Do not reverse the polarity.

Operating the device safely



WARNING! Explosion hazard

- > Only use the device in closed, well-ventilated rooms.
- > Do not operate the device near flammable fumes or gases.
- > Ensure that the air inlets and outlets (e.g. ventilation grilles) of the device are not covered. Ensure good ventilation around the device.



WARNING! Electrocutation hazard

- > Do not use the device if the device itself or its connection cables are visibly damaged.
- > Before starting the device, ensure that all cables and connections are dry, and free of dirt or corrosion.
- > Always disconnect the power supply when working on the device.
- > Observe that parts of the device may still conduct voltage even if the fuse has blown.
- > Do not disconnect any cables when the device is still in use.



NOTICE! Damage hazard

- > Do **not** use the device near aggressive vapors or combustible materials, or in potentially explosive areas.
- > Do not place the device near heat sources (heaters, direct sunlight, gas ovens, etc.).
- > Only use accessories that are recommended by the manufacturer.
- > DO NOT MODIFY OR ADAPT ANY OF THE COMPONENTS IN ANY WAY.

Safety when handling batteries



WARNING! Fire hazard

- > Only use rechargeable batteries. Do not attempt to charge non-rechargeable batteries.



WARNING! Risk of injury

- > Batteries contain aggressive and caustic acids. Avoid battery fluid coming into contact with your body. If your skin does come into contact with battery fluid, wash that part of your body thoroughly with water. If you sustain any injuries from acids, contact a doctor immediately.
- > Wear goggles and protective clothing when working on batteries. Do not touch your eyes when working on batteries.
- > When working on batteries, do not wear any metal objects such as watches or rings. Lead acid batteries can cause short circuits which can cause serious injuries.
- > Only use insulated tools.
- > Do not place any metal parts on the battery and prevent any metal parts from falling on the battery. This can cause sparks or short-circuits the battery and other electrical devices.



CAUTION! Explosion hazard

- > Never attempt to charge a frozen or defective battery. Place the battery in a frost-free area and wait until the battery has acclimatised to the ambient temperature. Then start the charging process.
- > Do not smoke, use an open flame, or cause sparking near the engine or a battery.



NOTICE! Damage hazard

- > Ensure that the polarity is correct when connecting the battery.
- > Follow the instructions of the battery manufacturer and those of the manufacturer of the system or vehicle in which the battery is used.
- > If the battery has to be removed, disconnect the negative pole (ground connection) before disconnecting the positive pole to avoid a short circuit. Disconnect all connections and all consumers from the battery before removing it.
- > Only store fully charged batteries. Recharge stored batteries regularly.
- > Do not carry the battery by its terminals.

Special precautions for vented lead acid (VLA) batteries



CAUTION! Health hazard

- > The water-acid liquid inside the battery can evaporate and cause an acidic odor. Use the battery only in a well-ventilated area.



NOTICE! Damage hazard

- > The battery is not sealed. Do not turn the battery on its side or upside down. Place the battery on a horizontal surface.
- > Check the acid level for open lead acid batteries regularly.
- > Immediately recharge deeply discharged lead acid batteries to avoid sulfation.

Special precautions for lithium batteries



CAUTION! Risk of injury

- > Only use batteries with integrated battery management system and cell balancing.



NOTICE! Damage hazard

- > Only install the battery in environments with an ambient temperature of at least 0 °C.
- > Avoid deep discharge of the batteries.

4 Scope of delivery

Description	Quantity
Battery charger	1
Display panel for remote control with cable (RJ12)	1
Short Installation and Operating manual	1

5 Accessories

Available as accessories (not included in the scope of delivery):

Designation	Ref. no.
Temperature sensor with cable (7.5 m)	EN3TEMP

6 Intended use

The battery charger is intended to charge house batteries in vehicles (e.g. recreational vehicles, boats, trucks) from the alternator or solar system while driving. In addition, the device can be used as a stable power supply for consumers to keep the batteries fully charged.

The battery charger is intended to be used to charge the following battery types:

- Vented lead acid (VLA) batteries
- Sealed lead acid (SLA) batteries
- Absorbed glass mat (AGM) batteries
- LiFePO4 batteries

The battery charger is **not** intended to be used to charge other types of batteries (e.g., NiCd, NiMH, etc.).

The battery charger is suitable for:

- Mobile use
- Indoor use
- Use in marine environments
- Parallel connection with other battery chargers
- Service workshops or commercial use

The battery charger is **not** suitable for:

- Mains operation
- Outdoor use

The display is intended for programming the battery charger and for monitoring and displaying real-time information, such as the charging current and the input voltages.

This product is only suitable for the intended purpose and application in accordance with these instructions.

This manual provides information that is necessary for proper installation and/or operation of the product. Poor installation and/or improper operation or maintenance will result in unsatisfactory performance and a possible failure.

The manufacturer accepts no liability for any injury or damage to the product resulting from:

- Incorrect installation, assembly or connection, including excess voltage
- Incorrect maintenance or use of spare parts other than original spare parts provided by the manufacturer
- Alterations to the product without express permission from the manufacturer
- Use for purposes other than those described in this manual

Dometic reserves the right to change product appearance and product specifications.

7 Technical description

7.1 General description

The battery charger can be adapted to different battery types.

The battery charger offers the following functions:

- Microprocessor-controlled, temperature-compensated IUOU charging programs for various battery types
- Maximum power point tracking (MPPT)
- Smart charging function for automatic power regulation depending on the connected loads
- Battery equalization for VLA batteries

The battery charger has the following protective mechanisms:

- High voltage protection
- Low voltage protection
- High temperature protection
- Low temperature protection (only LiFePO₄ batteries with connected temperature sensor)
- Battery high temperature protection (only with connected temperature sensor)
- Reverse current protection
- Short circuit protection
- Reverse polarity protection for solar panel inputs

The battery charger is supplied with a display panel for remote control. The display is an LCD digital display with back lighting.

A temperature sensor (accessories) can be connected to monitor the battery temperature during the charging process.

7.2 Connections

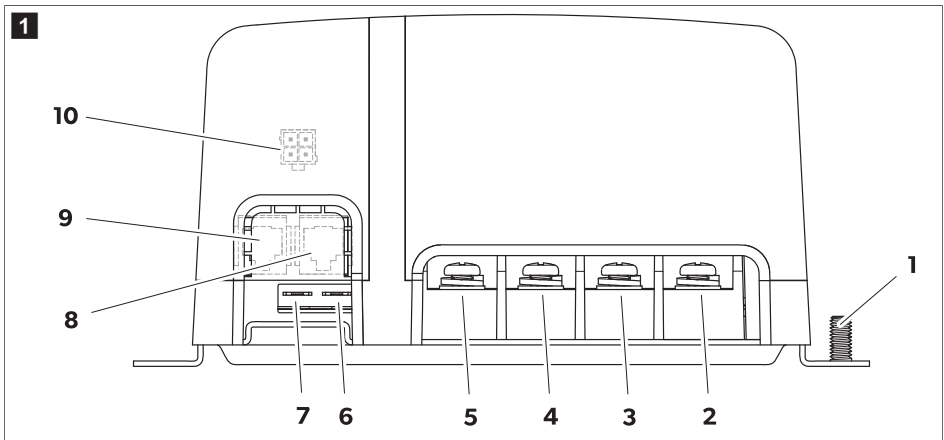





No. in Fig. 1 on page 7	Description
1	Ground connection

No. in Fig. 1 on page 7	Description	
2	CH3	Connection to positive pole of starting battery/alternator
3	CH2	Connection to positive pole(s) of solar panel(s)
4	Neg	Common ground connection to negative pole of 12 V house battery/chassis, to negative pole of starting battery/alternator and to negative pole(s) of solar panel(s)
5	CH1	Connection to positive pole of 12 V house battery
6	COM1 port	Control of the input voltage range and the selectable start voltage (P2H/P2L) of CH3 (see chapter Connecting the COM1 port (optional) on page 16)
7	Ignition start port	Input for D+ signal of the alternator or ignition lock signal (terminal 15)
8	BTS port	Connection for temperature sensor
9	Remote port	Connection for display panel
10	CAN connection port	Communication port for use with CAN BUS communication system (optional)

7.3 Display panel

Control elements

Button	Designation	Description
	Power button	Switching the battery charger and the display on or off
	Menu button	<ul style="list-style-type: none"> • Display of input voltages of connected input/outputs and display codes (see chapter Displaying parameters on input and outputs on page 21) • Open and close the settings menu (see chapter Making settings on page 17)
	Setting button	<ul style="list-style-type: none"> • Confirm an option in the settings menu (see chapter Making settings on page 17) • Navigate forwards in the settings menu
	Select button	Switch between the possible options in the settings menu (see chapter Making settings on page 17)

Display code

Element	Status	Description	
bUL	on	I phase (Bulk)	Battery charging phase (see chapter Battery charging function on page 10)
Abs	on	U1 phase (Absorption)	
Flo	on	U2 phase (Float) (charging program GEL/AGM/Flooded/Custom setting)	
FuL	on	U2 phase (Float) (charging program Lithium)	
CH1	on	House battery is in I/U2 phase	See chapter Technical data on page 27 for information on input voltage ranges.
	off	CH1 is not connected	
CH2	on	House battery is charged via CH2	Availability of CH2/CH3 depends on the house battery priority setting (see chapter Setting the priority for house battery charging on page 18).
	flashing	CH2 is available and in the input voltage range, but in standby mode (battery is not charged via CH2)	
	off	CH2 is not available/not in the input voltage range	
CH3	on	House battery is charged via CH3	
	flashing	CH3 is available and in the input voltage range, but in standby mode (battery is not charged via CH3)	
	off	CH3 is not available/not in the input voltage range	
CHE	flashing	CH3 input voltage check (only when charging via CH3), flashes every 3 min for 5 s While CHE is displayed, the charging process via CH3 is paused and the voltage is checked: <ul style="list-style-type: none"> voltage < low voltage recovery voltage: Charging process via CH3 is continued voltage > low voltage recovery voltage: Charging process via CH3 is ended 	See chapter Technical data on page 27 for information on the low voltage recovery voltage.
h_A	on	Selected bulk/absorption current in A.	See chapter Setting the charging current on page 19
L_A	on	Selected absorption-float current in A.	
Eq	flashing	Setting mode for battery equalization is active	Battery equalization (see chapter Activating the battery equalization function (only for VLA batteries) on page 22)
	on	Battery equalization is in progress	
rSt	flashing	Setting mode for the start charging function is active	Start charging function (see chapter Setting the start charging function on page 21)
	on	The start charging function is activated	
P2L	on	Signal connected to COM 1	Specification for input voltage range (see chapter Technical data on page 27)
P2H	on	No signal connected to COM 1	

Element	Status	Description	
rEC	on	Restart voltage	See chapter Setting the charging voltage on page 19
Lo	on	Temperature compensation set to Lo (low)	Temperature compensation setting (see chapter)
nor	on	Temperature compensation set to nor (normal)	
hi	on	Temperature compensation set to hi (high)	
AUTO	on	Silent mode activated	See chapter Setting the silent mode on page 21
Priority	on	The priority for house battery charging is set to P1 or P2.	See chapter Setting the priority for house battery charging on page 18
u_...	on	Revision of the battery charger	
r_...	on	Revision of the display panel	

7.4 Battery charging function

The charging characteristic ensures a fully automated charging cycle and charge retention over longer periods without monitoring.

A main charging cycle of the **house battery** is initiated after the house battery voltage has fallen below the set recharge voltage (rEC, see chapter Setting the charging voltage on page 19).

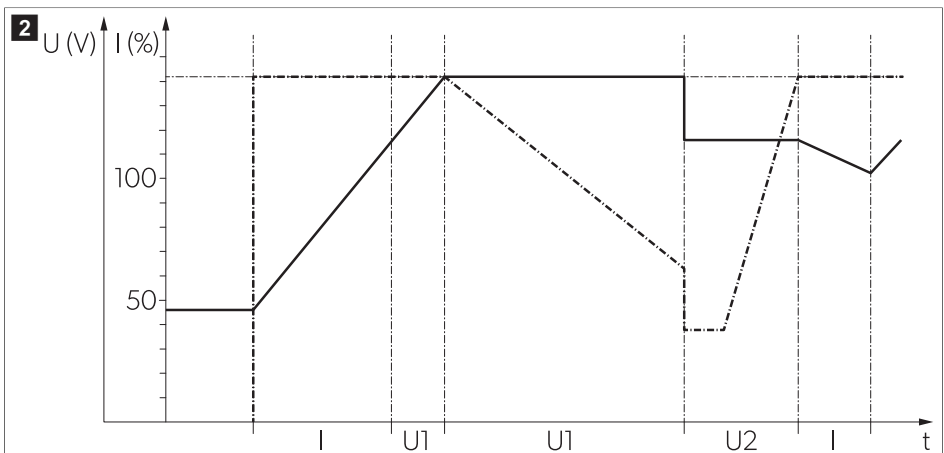

1: I phase (Constant current phase – Bulk)

At the beginning of the charging process, the empty battery is constantly charged with the set maximum charging current ($A_{I/U1}$, see chapter Setting the charging current on page 19).

2: U1 phase (Constant voltage phase – Absorption)

The U1 phase starts when the battery has reached a state of charge of 80%. The charging current is reduced. During the U1 phase, the battery voltage is kept constant at a high level. The duration of the U1 phase depends on the battery type and the set absorption-float current (A_{U-} , see chapter Setting the charging current on page 19).

The U2 phase is limited to 5 – 8 h depending on the battery type.

3: U2 phase (Trickle charging – Float)

The U2 phase serves to maintain the battery capacity (100 %). The U2 phase runs at lowered charging voltage and variable current. If DC loads are connected, they are powered by the device. Only if the power required exceeds the capacity of the device is this surplus power provided by the battery. The battery is then discharged until the device re-enters the I phase and charges the battery.

7.5 Battery temperature compensation

VLA, SLA, AGM: With the temperature sensor (accessories) connected, the battery charger adjusts the charging voltage according to the measured temperature at the house battery (see table). The temperature sensor detects overheating of the battery (battery exceeds cut-off values) and switches the battery charger to high temperature protection (see chapter *Warning codes* on page 24)/high temperature shutdown (see chapter *Error codes* on page 24).

Lithium: With the temperature sensor (accessories) connected, the battery charger is switched to high temperature shutdown/low temperature shutdown if the temperature sensor detects overheating/undercooling of the battery (battery exceeds cut-off values) (see chapter *Error codes* on page 24).

Without the temperature sensor connected, the battery temperature compensation needs to be adjusted manually (see chapter *Setting the battery temperature compensation manually* on page 20).

House battery temperature measured	Voltage adjustment in relation to an average temperature of 25 °C	
< 25 °C	VLA, SLA	0.03 V / 0 °C
	AGM	0.02 V / 0 °C
	Lithium	–
25 °C		0V
> 25 °C	VLA, SLA	0.03 V / 0 °C
	AGM	0.02 V / 0 °C
	Lithium	–

8 Installation

8.1 Installation location

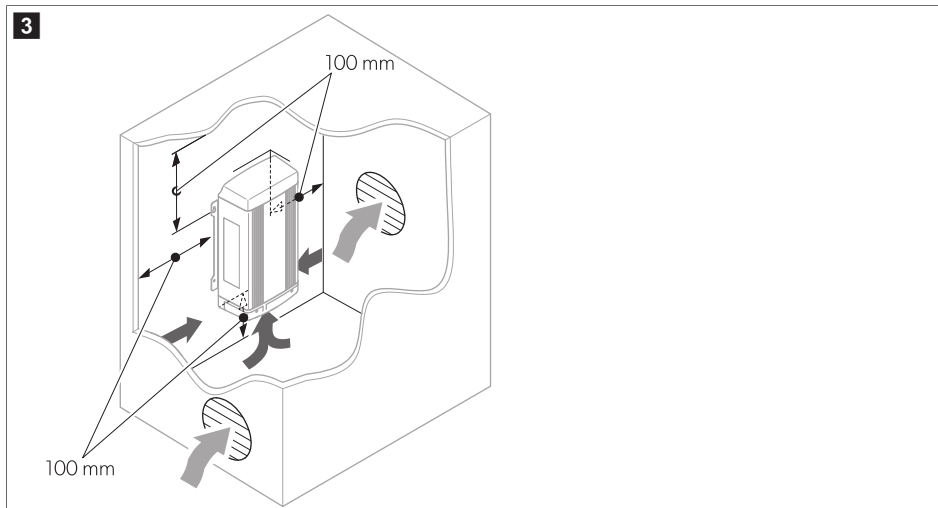

Observe the following instructions when selecting an installation location:

- Ensure that the mounting surface is solid and level.
- Observe the distance specifications ( Fig. **3** on page 12).

8.2 Mounting the battery charger

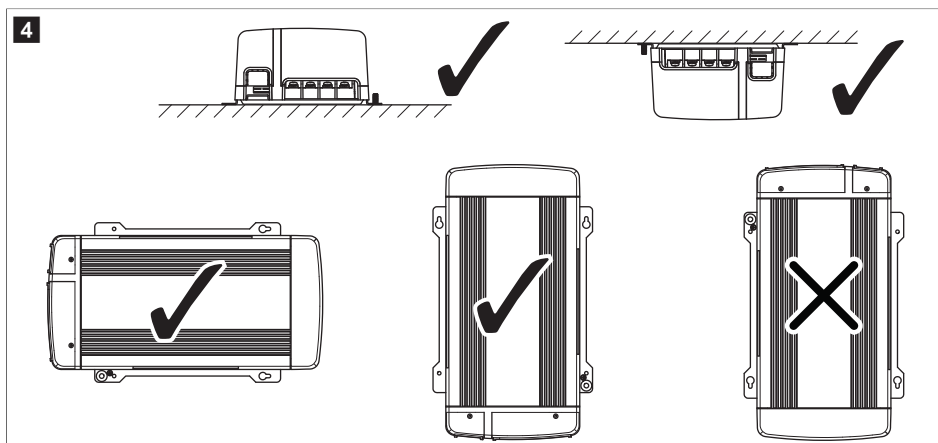

NOTICE! Damage hazard

- > Before drilling any holes, ensure that no electrical cables or other parts of the vehicle can be damaged by drilling, sawing and filing.



NOTE The battery charger can be installed lying as well as hanging ( Fig. 4 on page 12).

- Mount the device vertically (with the battery terminals facing downwards) for optimal thermal performance and drip water protection.
- Do not mount the device upside down.

1. Hold the battery charger at the desired mounting location and mark the mounting holes.
2. Pre-drill the mounting holes.
3. Screw the battery charger in place.

8.3 Connecting the battery charger



The electrical installation and setup of the device must be performed by a qualified electrician who has demonstrated skill and knowledge related to the construction and operation of electrical equipment and installations, and who is familiar with the applicable regulations of the country in which the equipment is to be installed and/or used, and has received safety training to identify and avoid the hazards involved. All other actions are intended also for non-professional users.



WARNING! Electrocuting hazard

- > Observe the recommended cable cross-sections, cable length and fuse(s).



CAUTION! Fire hazard

- > Place the fuses near the batteries to protect the cable from short circuits and possible burning.



NOTICE! Damage hazard

- > Do not reverse the polarity.

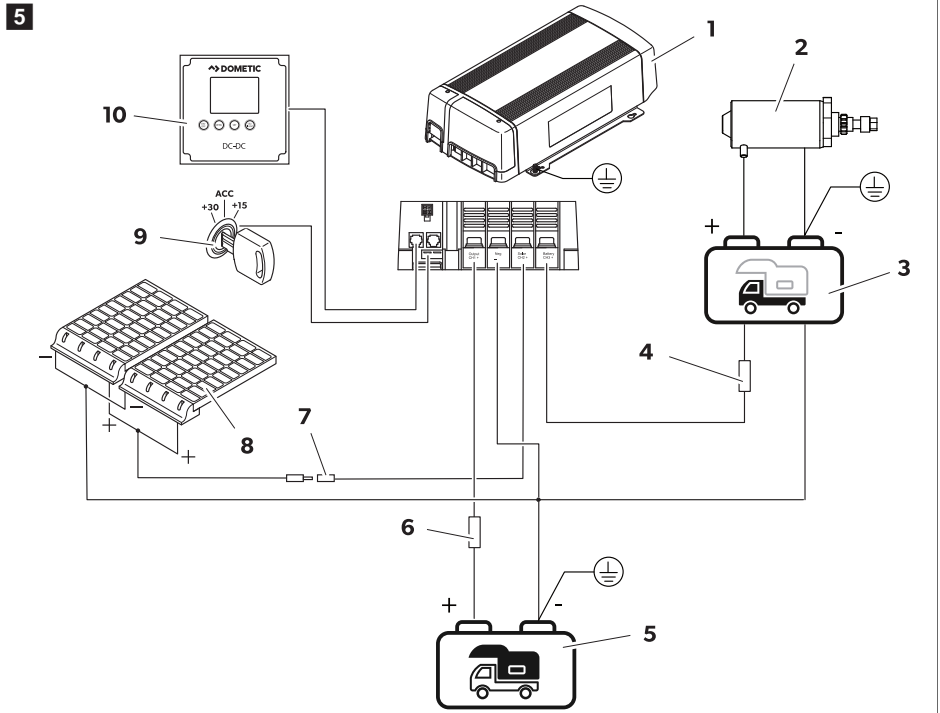

No. in Fig. 5 on page 14	Description	No. in Fig. 5 on page 14	Description
1	Battery charger	6	Fuse (150 A)
2	Alternator	7	DC circuit breaker
3	12 V starting battery	8	Solar system
4	Fuse (120 A)	9	Ignition
5	12 V house battery	10	Display

Observe the following instructions when connecting the battery charger:

- Always connect the battery charger before connecting the batteries.
- Connect the probe of the temperature sensor (accessories) to the negative terminal of the house battery.
- Protect the positive cable of the house battery with a fuse I (4).
- Protect the positive cable of the starting battery with a fuse II (6).
- Install a DC circuit breaker (8) between the solar panel(s) and the battery charger. Ensure that the DC circuit breaker is suitable for the calculated current and voltage.
- Determine the cable cross-section and fuses for CH1 and CH3 with a **cable length** of < 1.5 m.

	Cable cross-section	Fuse/circuit breaker
CH1	35 mm ²	120 A
CH3	35 mm ²	120 A
	50 mm ²	150 A

- Determine the cable cross-section and fuses for CH2 based on the solar system used with a **cable length** of < 6 m.

Solar system	Cable cross-section and fuse/circuit breaker					
(12 V)	1 panel	2 panels	3 panels	4 panels	5 panels	6 panels
200 Wh	5.3 mm ² , 15 A	13.3 mm ² , 30 A	13.3 mm ² , 40 A	21.2 mm ² , 50 A	21.2 mm ² , 60 A	33.6 mm ² , 80 A
400 Wh	13.3 mm ² , 30 A	21.2 mm ² , 50 A	33.6 mm ² , 80 A	–	–	–

- Connect the ignition start port to the vehicle's ignition start signal (D+ signal of the alternator or ignition lock signal (terminal 15)).

Connecting the charging output and inputs

(CH1, CH2, CH3, Neg)

1. Loosen the two screws on the top of the connection compartment to remove the plastic cover.
2. Connect the positive pole of the house battery to CH1.
3. Connect the negative pole of the house battery to Neg.
4. Connect the positive pole of the starting battery/vehicle's alternator to CH3.
5. Connect the negative pole of the starting battery to Neg.
6. Connect the positive pole(s) of the solar panel(s) to CH2.
7. Connect the negative pole(s) of the solar panel(s) to Neg.
8. Tighten the screws on the charger terminals to a torque of 4 – 5 N·m.



NOTICE! Damage hazard

- > Use a torque wrench to ensure that the torque is correct. Too low a torque can lead to poor contact and loss of tension. Too high a torque can damage the screws or overstretch the thread.

9. Screw the plastic cover back onto the top of the connection compartment.

Connecting the display

- > Connect the RJ12 cable to the COM1 port on the back of the display panel and to the Remote port on the battery charger.

Connecting the temperature sensor

- > Connect the RJ12 plug of the temperature sensor to the BTS port on the battery charger.
- > Connect the probe of the temperature sensor to the negative terminal of the house battery.

Connecting the ignition start port (optional)



NOTE A connection to the ignition start port is necessary

- If the battery charger is to be switched on automatically when the engine of your vehicle is ignited (see chapter Switching the battery charger on or off on page 16).
- If the priority for house battery charging is set to **P1** (see chapter Setting the priority for house battery charging on page 18).

- > Connect an > 8 V voltage signal to the ignition start port, e.g. a fuse that only supplies power when the ignition is switched on.

Connecting the COM1 port (optional)

COM1 port controls the input voltage range and the selectable start voltage (threshold value) of CH3.

- If no signal is connected to COM1, the threshold value setting and input voltage range **P2H** (high voltage) is used.
- If a signal (8 – 17 V) is connected to COM1, the threshold value setting and input voltage range **P2L** (low voltage) is used.

A low threshold value (P2L) is required, for example, if the device is installed at some distance from the alternator or for vehicles with a smart alternator.

Related information

Setting the start voltage of CH3 on page 18

Technical data on page 27

Connecting the CAN port (optional)

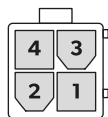

Pin	Explanation	Pin	Explanation
1	not connected	2	CAN low
3	CAN high	4	not connected

- > Connect the CAN plug to the CAN connection port, observing the pin assignment.

9 Operation

9.1 Switching the battery charger on or off



NOTE

- The battery charger switches on automatically if the ignition start port of the battery charger is connected to the ignition start signal of the vehicle as soon as an > 8 V voltage signal is present (see chapter Connecting the ignition start port (optional) on page 16). The device remains switched on even if the signal is removed.
- The battery charger switches on automatically by providing a > 20 V signal to CH2.
- The battery charger switches off automatically if CH2 and CH3 are outside the operating range for at least 3 min or not connected. E08 and E09 are displayed before the display switches off.
- Switch off the battery charger when it is not in use to avoid continuous current consumption from the house battery (reverse current) or the starting battery.

- > Press and hold on the display panel for 1 s to switch the battery charger on or off.

9.2 Switching the display on and off

The display switches **on** automatically as soon as a power source is connected to one of the inputs (CH2 and/or CH3) and the house battery is being charged.

The display switches **off** automatically as soon as the battery charger switches off (see chapter Switching the battery charger on or off on page 16).

9.3 Switching the display to standby mode

By default, the display automatically switches to standby mode after 60 s of inactivity (no buttons pressed).

In standby mode the display is dimmed.

9.4 Making settings



NOTE

- When the device is switched on for the first time (initial setup) or if settings are to be changed, the required settings must be made in the settings menu on the display.
- The display automatically returns to the main screen if no button is pressed for 15 s.
- **Mode** is displayed as long as the settings menu is open.

1. Press the **Menu** button for at least 3 s to open the settings menu.
 - ✓ The first setting for the device opens automatically.
2. Press the **Selection** button to switch between the possible options of the setting.
3. Press the **Setting** button to confirm an option.
 - ✓ The next setting for the device opens automatically.
4. Press the **Menu** button for at least 3 s to return to the main screen.

9.4.1 Setting the priority for house battery charging

> Set the priority for house battery charging based on the following table.

Priority setting	Charging input (first priority)	Condition	Charging input (second priority)	Explanation
P1 Alternator priority when ignition start signal available	CH3	Ignition start signal available	CH2	The house battery is primarily charged via CH3 (input alternator) when an ignition start signal is available. If no ignition start signal is available, the house battery is charged via CH2 (input solar panel). If CH3 with ignition start signal and CH2 are not available/not in the input voltage range, the battery is not charged.
P2 Alternator priority	CH3	–	CH2	The house battery is primarily charged via CH3 (input alternator). If CH3 is not available/not in the input voltage range, the house battery is charged via CH2 (input solar panel). If CH3 and CH2 are not available/not in the input voltage range, the battery is not charged.

9.4.2 Setting the charging program



NOTE *Custom setting: Setting for special batteries that require customized charging parameters. Ask the battery manufacturer about the recommended values.

> Set the charging program based on the battery type:

Battery type	Sealed lead acid (VLA) batteries	Absorbed glass mat (AGM) batteries	Vented lead acid (VLA) batteries	LiFePO4 batteries	*
Recommended charging program	GEL	AGM	Flooded	Lithium	Custom setting

✓ The charging program set is displayed.

9.4.3 Setting the start voltage of CH3



NOTE The selectable voltage range for the start up voltage depends on the connection at COM1 port (see chapter Connecting the COM1 port (optional) on page 16).

- > Set the start voltage of CH3 (input starting battery/alternator) in 0.1 V steps.

Selectable voltage range

P2L (low voltage)	signal connected to COM1:	11.5 – 12.7 V
P2H (high voltage)	no signal connected to COM1:	12.7 – 13.7 V

9.4.4 Setting the charging current

1. Set the bulk/absorption current in A (Bulk/Abs, $A_{I/U1}$).



NOTE

- Select the current settings based on the capacity of the house battery. It is recommended to set the bulk/absorption current ($A_{I/U1}$) to a maximum of 1/5 of the battery capacity in Ah, e.g. set ≤ 40 A for a battery capacity of 200 Ah.
- The setting options are displayed as hxxA (x = selectable value for A).

2. Set the absorption-float current in A (Abs-Float, A_{U2}).



NOTE

- Select the current settings based on the bulk/absorption current ($A_{I/U1}$). It is recommended to set the absorption-float current (A_{U2}) to a maximum of 1/10 of the bulk/absorption current ($A_{I/U1}$).
- In the U2 phase, the DC output current available from the battery charger is limited to the absorption-float current setting (A_{U2}). Select the highest available current setting if a DC consumer is permanently connected to the house battery and switched on.
- The setting options are displayed as Lx A (x = selectable value for A).

Current setting available										
$A_{I/U1}$	10	20	30	40	50	60	70	80	90	100
A_{U2}	1/1.5/2	1/1.5/2	1/1.5/3	2/3/4	2/4/5	3/4/6	3/5/7	4/6/8	4/6/9	5/7/10

9.4.5 Setting the charging voltage



NOTICE! Damage hazard

- > Only use batteries that are suitable for the specified charging voltages.



NOTE

- **GEL, AGM, Flooded:** The restart voltage (rEC) can be selected within the specified range (see table) to a maximum of 0.2 V below the float voltage (U2).
- **Lithium:** The charging voltages and the restart voltage (rEC) can be selected within the specified range (see table). Ask the battery manufacturer about the maximum permissible voltages. The float voltage (U2) and the restart voltage (rEC) can only be set to at least 0.3 V below the bulk/absorption voltage (I/U1); the restart voltage (rEC) can only be set to at least 0.3 V below the float voltage (U2).
- **Custom setting:** The charging voltages and the restart voltage (rEC) can be selected within the specified range (see table). Ask the battery manufacturer about the maximum permissible voltages. The float voltage (U2) and the restart voltage (rEC) can only be set to at least 0.2 V below the bulk/absorption voltage (I/U1); the restart voltage (rEC) can only be set to at least 0.2 V below the float voltage (U2).

> Set the voltages for the battery type used within the selectable range (see table).

Charging program	Charging voltage		Restart voltage (rEC)
	I/U1 (bUL)	U2 (Flo)	
GEL	14.4 V	13.7 V	12.5 – 13.5 V (0.1 V step)
AGM	14.6 V	13.6 V	12.5 – 13.4 V (0.1 V step)
Flooded	14.4 V	13.3 V	12.5 – 13.1 V (0.1 V step)
Lithium	13.9 – 14.6 V (0.1 V step)	13.5 – 14.4 V (0.1 V step)	13.2 – 14.2 V (0.1 V step)
Custom setting	13.8 – 14.8 V (0.1 V step)	13 – 14.5 V (0.1 V step)	12.8 – 14.4 V (0.1 V step)

9.4.6 Setting the charging mode



NOTE

- **Mode 3:** 3-stage charging, consists of the charging phases I phase (Bulk), U1 phase (Absorption) and U2 phase (Float).
- **Mode 2:** 2-stage charging, consists of the charging phases I phase (Bulk) and U1 phase (Absorption).

> Set the charging mode to **Mode 3** or **Mode 2**.

Related information

Battery charging function on page 10

9.4.7 Setting the battery temperature compensation manually



NOTE

- For lithium batteries, select the battery temperature setting nor (Normal).
- For automated temperature compensation connect the temperature sensor (see chapter Connecting the temperature sensor on page 15).
- If the temperature sensor is connected, the temperature compensation setting is automatically deactivated.
- **Temp** is displayed while the temperature compensation is being set.

- > Select the appropriate temperature compensation setting based on the room temperature according to the following table.

Room temperature	Temperature compensation setting	Voltage adjustment in relation to an average temperature of 25 °C at setting nor	
< 5 °C	Lo (low)	VLA, SLA	0.68 V
		AGM	0.52 V
5 – 30 °C	nor (normal)	0 V	
> 30 °C	hi (high)	VLA, SLA	– 0.27 V
		AGM	– 0.21 V

9.4.8 Setting the silent mode

In silent mode the cooling fan is switched to the lowest speed (20 %) for quiet operation. The charging current is reduced (≤ 25 A).



NOTE When using the silent mode the system stays in this mode for 12 h and then automatically returns to normal operation.

- > Press and hold the **Selection** button for at least 3 s to activate the silent mode.
- ✓ **AUTO** is displayed.
- > Press and hold the **Selection** button for at least 3 s to deactivate the silent mode manually.

9.4.9 Setting the start charging function

(only for lithium or SLA batteries)

The start charging function can be activated to reset a lithium battery blocked by the battery's own BMS or to revive a heavily discharged sealed lead acid battery.



NOTE Ensure that the charging program is set to **lithium** (see chapter Setting the charging program on page 18).

1. Select **ON** to activate the start charging function.
- ✓ When the start charging function is activated, **zSt** is displayed on main screen.
12 V 1 A charging current are supplied to the house battery for 30 s and the function is deactivated automatically.
2. Select **OFF** to deactivate the start charging function.

9.5 Displaying parameters on input and outputs

During the charging process, the display on the main screen alternately shows the input voltage (V), the charging current (A) and the state of charge (buL, Abs, Flo, Ful) of CH1 (output house battery).

The display is switched on:

- > Press the **Menu** button for display of the input voltages of the connected inputs (CH2 and CH3).



NOTE

- The input voltages of the connected outputs are displayed for 3 s. The display automatically switches back to the main screen.
- If CH2 or CH3 are not connected to a power supply, 0 V and/or an error code is displayed for the output.

The display is switched off (no charging process, CH2 and CH3 are not connected to a power supply):

- > Press the **Menu** button for at least 3 s for display of CH1, CH2 and CH3 voltages and the display codes.

9.6 Activating the battery equalization function (only for VLA batteries)



WARNING! Explosion hazard

- > Only use the battery equalization function with vented lead acid (VLA) batteries to avoid overcharging the battery.
- > The battery produces explosive gases during battery equalization. Keep the battery away from ignition sources. Ensure that the battery and the surrounding area are well ventilated.



NOTICE! Damage hazard

- > Measure the specific gravity values of the battery regularly (at least once an hour) during battery equalization, e.g. by using a hydrometer or a digital density meter. Battery equalization is complete when the specific gravity values no longer increase, indicating the cells are fully charged and balanced. Consult the battery manufacturer's recommendations for specific details on checking electrolyte levels during battery equalization.



NOTE

- To activate the battery equalization function, the battery must be in the U2 phase (float).
- Ensure a sufficiently continuous power supply during battery equalization so that battery equalization can be completed.

1. Remove all DC loads from the battery.
2. Ensure that the battery type is set to **Flooded** (see chapter Setting the charging program on page 18).
3. Press and hold the **Setting** button and the **Selection** button simultaneously for at least 5 s to activate the setting mode for battery equalization.
 - ✓ **Eq** is displayed.
4. Press and hold the **Setting** button and the **Selection** button simultaneously for at least 5 s to start the battery equalization process.
 - ✓ **Eq** flashes.



NOTE

The battery charger is equipped with a time-out mode as an automatic safety function for the battery equalization process. The time-out mode prevents prolonged overcharging of the battery to protect the battery from possible damage.

The time-out mode interrupts the battery equalization process after 30 min. If no button is pressed during the time-out, the battery charger ends the process and returns to U2 phase (float) automatically.

5. If the battery charger has switched to time-out mode: Check the specific gravity values of the battery.
 - If further battery equalization is necessary: Press and hold the **Setting** button and the **Selection** button simultaneously for at least 5 s to reactivate the battery equalization function.
 - If battery equalization is complete: Wait for the time-out function to expire to end battery equalization automatically or press and hold the **Menu** button for more than 5 s to end battery equalization manually.

10 Cleaning and maintenance



WARNING! Electrocuting hazard

- > Disconnect the device from the power supply before each cleaning and maintenance.





NOTICE! Damage hazard

- > Never clean the device under running water or in dish water.
 - > Do not use sharp or hard objects, abrasive cleaning agents or bleach during cleaning as these can damage the device.
-
- > Occasionally clean the device with a soft, damp cloth.
 - > Regularly check live cables or lines for insulation faults, breaks or loose connections.
 - > VLA batteries only: Carry out the battery equalization function regularly (once a month to every 6 months, depending on the number of charging cycles) to remove sulphate layers (see chapter Activating the battery equalization function (only for VLA batteries) on page 22).

11 Troubleshooting

Problem	Possible cause	Suggested remedy
The battery charger does not work.	Insulation faults, breaks or loose connections at the live cables.	Check live cables for insulation faults, breaks or loose connections. If you cannot find an error, contact an authorized service agent.
	Short circuit has been generated.	The device fuse must be replaced by an authorized service agent after it has been triggered by excess current.
The charging process is interrupted, the battery is not detected.	Only for LiFePO4 batteries with battery management system: The battery management system (BMS) of the lithium battery has blocked the battery to protect it from damage (e.g. due to over voltage, deep discharge, overheating).	<ol style="list-style-type: none"> 1. Determine and rectify the cause of the blockage. 2. Activate the start charging function to release the blockage (Setting the start charging function on page 21). 3. If the lithium battery remains blocked: Contact the battery manufacturer for information on how to unblock the battery.

11.1 Warning codes

Warning code	Possible cause	Suggested remedy
A01	<p>High temperature protection Overheating of the battery charger</p> <p>The battery charger switches to reduced charging current (50 %) when the internal temperature exceeds the cutoff value (> 60 °C).</p> <p> NOTE If the internal temperature does not drop below the cutoff value in the long term, the device is shut down (error code E06).</p>	<ul style="list-style-type: none"> • Check that the air inlets and outlets of the device are not covered or obstructed. • Check that the fan is working. • Ensure there is sufficient ventilation around the device and observe the distance specifications (see chapter Installation location on page 12). <p>The warning code disappears automatically when the internal temperature drops to the restart value (< 58 °C).</p>
A02	<p>High temperature protection Overheating of the house battery</p> <p>The temperature of the battery exceeds the cutoff value (> 58 °C).</p> <p> NOTE If the temperature of the battery does not drop below the cutoff value in the long term, the device is shut down (error code E07).</p>	<ul style="list-style-type: none"> • Ensure there is sufficient ventilation around the battery. • Check the setting of the charging current. Ensure that the charging current is not set too high for the type of battery used. • Allow the battery to cool down. <p>The warning code disappears automatically when the temperature of the battery drops to the restart value (< 56 °C).</p>

11.2 Error codes

Error code	Possible cause	Suggested remedy
E01	<p>Over voltage protection Input voltage too high (CH3 > 16 V) when starting the device</p>	<ul style="list-style-type: none"> • Check the starting battery and the alternator. • Reduce the connected voltages. <p>The battery charger restarts automatically when the voltage drops to the restart value (< 52 V).</p>
E02	<p>Low voltage protection Input voltage too low (CH3 < P2L/P2H) during operation</p> <p>Low voltage protection Input voltage too low (CH3 < 10.5 V) when starting the device</p>	<ul style="list-style-type: none"> • Check the set values for P2L/P2H. • Check the connections at CH3. • Check the cable cross-sections and lengths.
E09	<p>Low voltage protection Input voltage too low (CH3 < 7 V) when starting the device</p>	<ul style="list-style-type: none"> • Check the starting battery and the alternator.

Error code	Possible cause	Suggested remedy
E03	<p>Over voltage shutdown* Solar panel voltage (voltage in open circuit, VoC) too high (CH2 > 55 V)</p> <p>*The charging process is stopped.</p>	<ul style="list-style-type: none"> • Check the solar panel voltage and ensure that Voc does not exceed 55 V. Reduce the number of connected solar panels if necessary. <p>The battery charger restarts automatically when the voltage drops to the restart value (< 52 V).</p>
E04	<p>Low voltage protection Input voltage too low (CH2 < 14.5 V) when starting the device</p> <hr/> <p>Low voltage protection Input voltage too low (CH2 < 16.5 V) during operation</p>	<ul style="list-style-type: none"> • The generated solar power is too low. Objects or dirt are blocking out light at the solar panels. • Check for obstructions and ensure that the solar panels are not blocked by shadows. • Remove any dirt.
E08	<p>Low voltage protection Input voltage too low (CH2 < 13 V) when starting the device</p>	<ul style="list-style-type: none"> • Move the vehicle to a more suitable location. • Overheating of the solar panels. <ul style="list-style-type: none"> • Allow the solar panels to cool down. • Move the vehicle to a more suitable location. • Ensure sufficient air circulation around the solar panels. • Solar panel(s) in the array failed. <ul style="list-style-type: none"> • Check the solar panels for micro cracks and delamination. • Replace defective solar panels. • Check the connections at CH2. • Check the cable cross-sections and lengths.
E05	<p>Over voltage shutdown* Input voltage too high (CH1 > 16 V)</p> <p>*The charging process is stopped.</p>	<ul style="list-style-type: none"> • Charging voltages too high. Reduce the connected voltages. • Connection of defective charging systems. Check and remove defective charging systems if necessary. <p>The battery charger restarts automatically when the voltage drops to the restart value (< 15.5 V).</p>
E06	<p>High temperature shutdown* Overheating of the battery charger</p> <p>The internal temperature of the battery charger exceeds the cutoff value (65 °C).</p> <p>*The charging process is stopped.</p>	<ul style="list-style-type: none"> • Check that the air inlets and outlets of the device are not covered or obstructed. • Check that the fan is working. • Ensure there is sufficient ventilation around the device and observe the distance specifications (see chapter Installation location on page 12). <p>The battery charger restarts automatically when the internal temperature drops to the restart value (< 40 °C).</p>

Error code	Possible cause	Suggested remedy
E07	High temperature shutdown* Overheating of the house battery The temperature of the battery exceeds the cutoff value ($> 60\text{ }^{\circ}\text{C}$). *The charging process is stopped.	<ul style="list-style-type: none"> • Ensure there is sufficient ventilation around the battery. • Check the setting of the charging current. Ensure that the charging current is not set too high for the type of battery used. • Have the batteries checked for any faults by a specialist. Replace defective batteries if necessary. <p>The battery charger restarts automatically when the temperature of the battery drops to the restart value ($< 56\text{ }^{\circ}\text{C}$).</p>
	Defective temperature sensor	<ul style="list-style-type: none"> • Contact an authorized service agent.
E10	Short circuit has been generated (CH1)	<ul style="list-style-type: none"> • Reverse polarity protection. Check the right polarity of the house battery wiring. • Short circuit protection. Activation of the short circuit protective mechanism renders the device inoperable and cannot be reset, bypassed, or otherwise remedied by the user. Such activation constitutes a fault condition that may only be inspected and repaired by an authorized service technician. All expenses incurred in connection with diagnosis, repair, replacement of parts, handling, and transportation shall be the sole responsibility of the owner.
E11	No connection from the battery charger to the house battery (CH1).	<ul style="list-style-type: none"> • Check the connections.
E12	Low temperature shutdown* (only for LiFePO4 batteries) The temperature of the battery drops below the cutoff value ($\leq 0\text{ }^{\circ}\text{C}$) *The charging process is stopped.	<ul style="list-style-type: none"> • Move the battery to another location ($> 0\text{ }^{\circ}\text{C}$). <p>The battery charger restarts automatically when the temperature of the battery rises to the restart value ($> 0\text{ }^{\circ}\text{C}$).</p>

12 Disposal



Recycling packaging material: Place the packaging material in the appropriate recycling waste bins wherever possible.



Recycling products with non-replaceable batteries, rechargeable batteries, or light sources:

- If the product contains any non-replaceable batteries, rechargeable batteries, or light sources, you don't have to remove them before disposal.
- If you wish to finally dispose of the product, ask your local recycling center or specialist dealer for details about how to do this in accordance with the applicable disposal regulations.

13 Warranty

If the product does not work as it should, please contact your retailer or the manufacturer's branch in your country (see enerdrive.com.au). The warranty applicable to your product is 5 year(s).

For repair and warranty processing, please include the following documents when you send in the device:

- A copy of the receipt with purchasing date
- A reason for the claim or description of the fault

Note that self-repair or nonprofessional repair can have safety consequences and might void the warranty.

Our goods come with guarantees that cannot be excluded under the Australian Consumer Law. You are entitled to a replacement or refund for a major failure and for compensation for any other reasonably foreseeable loss or damage. You are also entitled to have the goods repaired or replaced if the goods fail to be of acceptable quality and the failure does not amount to a major failure. The benefits provided to you as the consumer by this warranty are in addition to other rights and remedies available to you under the law.

This warranty policy is subject to the conditions and guarantees which are mandatory as implied by the Consumer Guarantees Act 1993(NZ).

14 Technical data

	EN3DC100
Charging output house battery (CH1)	
Nominal battery voltage	12 V ⁻⁻⁻
Charging current	100 A
Max. power output	1400 W
Reverse current from battery, stand-by	
• With unit ON	< 600 mA
• With unit OFF	< 1 mA
Minimum battery voltage for start of charging	8 V ⁻⁻⁻
Recommended battery capacity	
• Lead Acid/AGM batteries	> 500 Ah
• Lithium batteries	> 200 Ah
Charging input solar panel (CH2)	
Input voltage range	16.5 – 55 V
Max. input current	80 A
Max. input power	1200 W
Charging mechanism	MPPT
Charging input starting battery/alternator (CH3)	
Input voltage range	10.5 – 16 V
• P2L (signal connected to COM 1)	11.5 – 12.7 V
• P2H (no signal connected to COM 1)	12.7 – 13.7 V

	EN3DC100
Low voltage recovery voltage	
<ul style="list-style-type: none"> • for P2L (signal connected to COM 1) 11.3 V • for P2H (no signal connected to COM 1) 12.3 V 	
Max. input current	135 A
General technical data	
Protection type	IP32
Optimal temperature range (no derating)	-20 °C ... 40 °C
Ambient temperature for operation	-20 °C ... 60 °C
Storage temperature	-40 °C ... 70 °C
Ambient humidity	5 ... 95 %, non-condensing
Dimensions (W x D x H)	356 x 205 x 97 mm
Weight	3.23 kg
Certification	



enerdrive.com.au

YOUR LOCAL SUPPORT

support.enerdrive@dometic.com

call 1300 851 535

A complete list of Dometic companies, which comprise the Dometic Group, can be found in the public filings of:
DOMETIC GROUP AB • Hemvärnsgatan 15 • SE-17154 Solna • Sweden