

ALVOLTA AMG/MEGA INPUT MODULE

ALV-AMG-IM

Key Features:



Input Module



Modular System



M8 Stud



Protective Cover



Durable Design

Suitable for:



3 YEAR
WARRANTY

ALVOLTA AMG/MEGA INPUT MODULE

ALV-AMG-IM

Specifications:

Maximum Voltage	24V DC
Maximum Holder Current	400A
Maximum Current With Linking Plates Connected	600A
Fuse Type	AMG/Mega Fuses
Stud Type	M8 (8mm)
Stud Material	Stainless Steel
Cover Material	Red Silicon
Base Material	PPS Plastic
Colour	Black with Red Cover
Dimensions	121.7 x 34.4 x 41.2mm

Model Diagram:

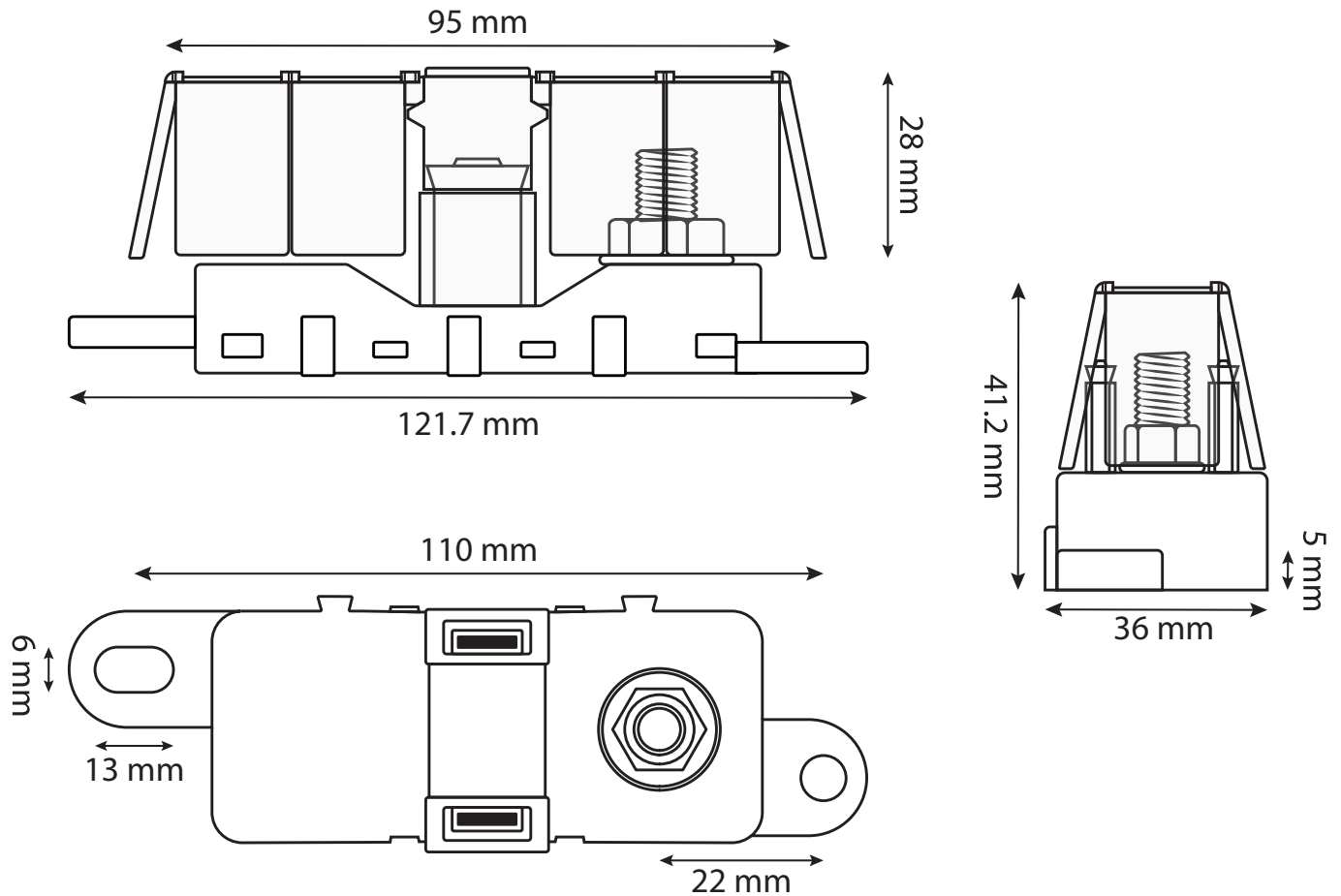

*All data and specifications provided in this datasheet are tested under standard test conditions, and may deviate marginally from actual values. Alvolta and its associates reserve the right to make modifications to the provided information without notice. Alvolta maintains the goal to supply customers with the most recent information regarding its products.

ALVOLTA AMG/MEGA INPUT MODULE

ALV-AMG-IM

Modular Connection Diagrams:

